

**STEINLEN**  
ELEKTRISCHE ANTRIEBSTECHNIK

**MOTOX/MOTOX<sup>®</sup>-N**

Operating Instructions

**MOTOX**

Optional add-on units

BA 2510

Edition

3/2021



# Optional add-on units

## BA 2510

### Compact Operating Instructions

#### Translation of the original instructions

#### Legal information

#### Warning notice system

This manual contains notices you have to observe in order to ensure your personal safety, as well as to prevent damage to property. The notices referring to your personal safety are highlighted in the manual by a safety alert symbol, notices referring only to property damage have no safety alert symbol. These notices shown below are graded according to the degree of danger.

<b>⚠ DANGER</b>
indicates that death or severe personal injury <b>will</b> result if proper precautions are not taken.
<b>⚠ WARNING</b>
indicates that death or severe personal injury <b>may</b> result if proper precautions are not taken.
<b>⚠ CAUTION</b>
indicates that minor personal injury can result if proper precautions are not taken.
<b>NOTICE</b>
indicates that property damage can result if proper precautions are not taken.

If more than one degree of danger is present, the warning notice representing the highest degree of danger will be used. A notice warning of injury to persons with a safety alert symbol may also include a warning relating to property damage.

#### Qualified Personnel

The product/system described in this documentation may be operated only by **personnel qualified** for the specific task in accordance with the relevant documentation, in particular its warning notices and safety instructions. Qualified personnel are those who, based on their training and experience, are capable of identifying risks and avoiding potential hazards when working with these products/systems.

#### Proper use of Steinlen products

Note the following:

<b>⚠ WARNING</b>
Steinlen products may only be used for the applications described in the catalog and in the relevant technical documentation. If products and components from other manufacturers are used, these must be recommended or approved by Steinlen. Proper transport, storage, installation, assembly, commissioning, operation and maintenance are required to ensure that the products operate safely and without any problems. The permissible ambient conditions must be complied with. The information in the relevant documentation must be observed.

## 1 General information and safety instructions

### 1.1 General information

#### Note

Steinlen Elektromaschinenbau GmbH does not accept any liability for damage and failures that result from the non-observance of these operating instructions.

These operating instructions are part of the gearbox delivery. Store the operating instructions near the gearbox.

These operating instructions supplement the MOTOX gearbox operating instructions BA 2010.

They cover the optional flanges and seals for the standard version of the MOTOX gearbox:

- Agitator flange for helical gearbox DR/ZR sizes 68 to 168
- Mixer flange for parallel shaft gearbox FD.M/FZ.M sizes 88B to 168B and bevel helical gearbox K.M sizes 88 to 168
- Extruder flange for parallel shaft gearbox FDAE/FZAE sizes 68B to 168B and bevel helical gearbox KAE sizes 68 to 168
- Labyrinth seal
- Dry-well version
- Gearbox cooling

Table 1-1 Order number code

MOTOX gearbox	Order number location					
	1	2	3	4	5	14
Helical gearbox Z with agitator flange	S	T	3	1	1	R
Helical gearbox D with agitator flange	S	T	3	1	2	R
Parallel shaft gearbox FZ with mixer flange	S	T	3	1	3	M
Parallel shaft gearbox FD with mixer flange	S	T	3	1	4	M
Bevel helical gearbox K with mixer flange	S	T	3	1	5	M
Parallel shaft gearbox FZ with extruder flange	S	T	3	1	3	E
Parallel shaft gearbox FD with extruder flange	S	T	3	1	4	E
Bevel helical gearbox K with extruder flange	S	T	3	1	5	E

#### Note

In addition to these operating instructions, special contractual agreements and technical documentation apply to special gearbox designs and the associated supplementary equipment.

Please read these operating instructions and the operating instructions for the MOTOX gearbox BA 2010 before working with the gearbox.

Please refer to the other operating instructions supplied with the product.

The described gearboxes correspond to the state-of-the-art at the time these operating instructions were printed.

Steinlen Elektromaschinenbau GmbH reserves the right to change individual components and accessory parts in the interest of further development. The changes serve to improve the performance and safety. The significant features are retained. The operating instructions are updated regularly with new contents.

The latest versions of the operating instructions, the declaration of incorporation and the declarations of conformity are available in electronic form in the Online Support (<https://www.steinlen.eu>).

#### Valid operating instructions for MOTOX

- BA 2010 - operating instructions for MOTOX gearboxes
- BA 2011 - operating instructions for MOTOX worm gearbox SC
- BA 2019 - operating instructions for MOTOX input units
- BA 2310 - operating instructions for three-phase and single-phase AC motors and motors equipped with brake with accessories
- BA 2320 - operating instructions for LA/LG and LAI/LGI motors
- BA 2330 - operating instructions for LA/LE/LES motors
- BA 2510 - operating instructions for MOTOX optional add-on units
- BA 2515 - operating instructions for MOTOX gearboxes for overhead conveyors

## 1.2 Copyright

The copyright to these operating instructions is held by Steinlen Elektromaschinenbau GmbH.

These operating instructions must not be wholly or partly reproduced for competitive purposes, used in any unauthorized way or made available to third parties without agreement of Steinlen Elektromaschinenbau GmbH.

## 1.3 Intended use



### ATEX version gearboxes

The ATEX gearbox satisfies the requirements of the Explosion Protection Directive 2014/34/EU.

In the case of ATEX version gearboxes, please observe instructions marked with this symbol.

The MOTOX gearboxes described in these operating instructions have been designed for stationary use in general engineering applications.

Unless otherwise agreed, the gearboxes have been designed for use in machinery and plants in industrial environments.

The gearboxes have been built using state-of-the-art technology and are shipped in an operationally reliable condition. Changes made by users could affect this operational reliability and are forbidden.

---

### Note

The performance data assumes an ambient temperature of -20° C to +40° C and an installation altitude of up to 5000 m above sea level.

In the case of other ambient temperatures and installation altitudes, please contact Technical Support.

---

The gearboxes are designed only for the area of application described in Chapter Technical data in the operating instructions BA 2010 or BA 2515 for MOTOX gearboxes

Do not operate the gearboxes outside the specified performance limits.

Any different operating conditions require new contractual agreements.

Do not climb on the gearbox. Do not place any objects on the gearbox.

## 1.4 Obligations of the user

The operator must ensure that all persons assigned to work on the geared motor have read and understood these operating instructions and that they follow them in all points in order to:

- Eliminate the risk to life and limb of users and other persons.
- Ensure the operational safety of the geared motor.
- Avoid disruptions and environmental damage through incorrect use.

### Note the following safety information:

Shut down the geared motors and disconnect the power before you carry out any work on them.

Make sure that the drive unit cannot be turned on accidentally, e.g. lock the key-operated switch. Place a warning notice at the drive connection point which clearly indicates that work is in progress on the geared motor.

Carry out all work with great care and with due regard to "safety".

For all work, observe the relevant regulations for work safety and environment protection.

Read the instructions on the rating plates attached to the geared motor. The rating plates must be kept free from paint and dirt at all times. Replace any missing rating plates.

In the event of changes during operation, switch off the drive unit immediately.

Take appropriate protective measures to prevent accidental contact with rotating drive parts, such as couplings, gear wheels or belt drives.

Take appropriate protective measures to prevent accidental contact with parts and equipment that heat up to over +70 °C during operation.

When removing protective equipment, keep fasteners in a safe place. Re-attach removed protective equipment before commissioning.

Collect and dispose of used oil in accordance with regulations. Remove oil spillages immediately with an oil-binding agent in compliance with environmental requirements.

Do not carry out any welding work on the geared motor. Do not use the geared motor as a grounding point for welding operations.

Carry out equipotential bonding in accordance with applicable regulations and directives by electro technology specialists.

Do not use high-pressure cleaning equipment or sharp-edged tools to clean the geared motor.

Observe the permissible tightening torque of the fastening bolts.

Replace damaged bolts with new bolts of the same type and strength class.

Steinlen Elektromaschinenbau GmbH accepts the warranty only for original spare parts.

The manufacturer who installs the geared motors in a plant must include the regulations contained in the operating instructions in its own operating instructions.

## 1.5 Particular types of hazards

### WARNING

#### **Extreme surface temperatures**

Hot surfaces over +55 °C pose a burn risk.

Cold surfaces below 0 °C pose a risk of damage due to freezing.

Do not touch the gearbox without protection.

### WARNING

#### **Hot, escaping oil**

Before starting any work wait until the oil has cooled down to below +30 °C.

### WARNING

#### **Poisonous vapors when working with solvents**

Avoid breathing in vapors when working with solvents.

Ensure adequate ventilation.

**! WARNING**  
**Risk of explosion when working with solvents**  
Ensure adequate ventilation.  
Do not smoke!

**! WARNING**  
**Risk of eye injury**  
Rotating parts can throw off small foreign particles such as sand or dust.  
Wear protective eyewear!

In addition to the prescribed personal protection gear, also wear suitable protective gloves and safety glasses.

## 2 Agitator flange

For helical gearbox DR/ZR sizes 68 to 168

### 2.1 Technical description

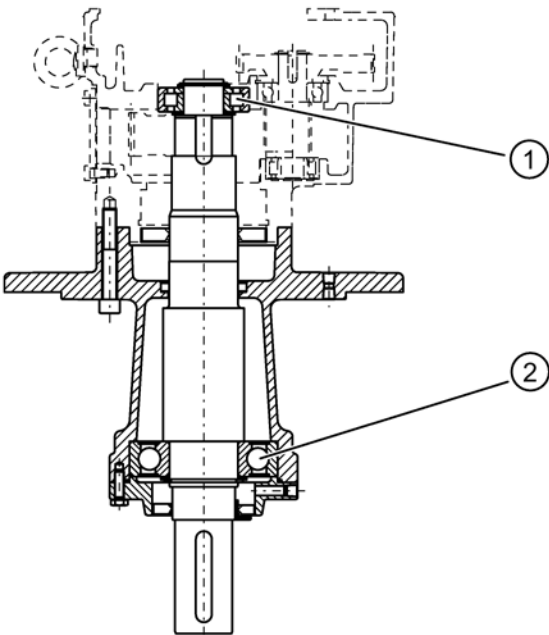

- ① Bearing in oil bath
- ② Greased bearing

Figure 2-1 Bearing in agitator flange

The multistage helical gearbox can be supplied with an upstream agitator flange.

With an upstream locating bearing, the bearing system is suitable for high external forces. The absorbed radial and axial loads are transmitted to the machine via the agitator flange.

The bearings in the agitator flange are lubricated independently of their design. The output-side bearing is greased. Initial greasing has already been carried out. The opposing bearing runs in a gearbox-oil bath.

The agitator flange can be optionally supplied with an automatic regreasing device, see Regreasing intervals (Page 6). In this case, the output-side bearing is not sealed with NILOS rings or caps.

## 2.2 Lubrication

In normal operating conditions and with low loads, the lubrication of the bearings is sufficient for approximately 25,000 to 30,000 operating hours.

For higher loads due to speed and / or temperature, schedule regreasing at shorter intervals.

### 2.2.1 Regreasing intervals

The regreasing interval is valid for a temperature of +70 °C, measured on the surface of the housing in the vicinity of the bearing.

---

#### Note

For temperatures above +70 °C, the regreasing interval must be reduced by half for each temperature increase of 15 K.

---

#### Note

For moderate shock loading and vibration, the regreasing interval must be reduced by 20 %.

For heavy loading, the regreasing interval must be reduced by half.

---

Regrease the bearing after the following number of operating hours.

Table 2-1 Regreasing intervals in operating hours for agitator flange

Output speed n <sub>2</sub>	Operating hours for size					
	68	88	108	128	148	168
[rpm]	[h]					
≤ 30	29 000	29 000	29 000	29 000	29 000	18 000
31 ... 50	29 000	29 000	29 000	29 000	14 000	14 000
51 ... 100	29 000	29 000	16 000	16 000	10 000	10 000
101 ... 150	29 000	29 000	14 000	12 000	9 000	7 000
151 ... 250	18 000	16 000	10 000	9 000	5 000	5 000
251 ... 400	14 000	12 000	7 000	7 000	4 000	4 000

### 2.2.2 Roller bearing grease

<b>NOTICE</b>
<b>When regreasing do not mix greases with different soap bases</b>

For regreasing, use lithium-saponified roller bearing grease NLGI 3/2.

Using a grease gun, inject the grease into the bearing point via the lubricating nipples provided.

The grease quantities listed in the table are guide values.

Table 2-2 Grease quantities for regreasing the agitator flange

Regreasing interval	Grease quantity for regreasing for size					
	68	88	108	128	148	168
	[g]					
After 6 months	20	20	50	60	70	70
After several years without operation	50	60	120	160	170	200



## 2.3 Maintenance of the output-side bearing in the agitator flange

### Note

Change the grease filling of the roller bearing when you change the gearbox oil.  
For refilling, use lithium-saponified roller bearing grease NLGI 3/2.

### Procedure

1. Dismantle the output-side bearing unit.
2. Clean the bearing.
3. Fill the bearing with the new grease up to approximately 30 % of the free bearing chamber.
4. Reassemble the bearing unit.

### Maintenance interval after regreasing

After regreasing, the maintenance interval can be increased to the following number of operating hours.

Table 2-3 Maintenance interval in operating hours after regreasing the agitator flange

Output speed $n_2$	Operating hours for size					
	68	88	108	128	148	168
[rpm]	[h]					
≤ 30	80 000	80 000	80 000	80 000	80 000	50 000
31 ... 50	80 000	80 000	80 000	80 000	40 000	40 000
51 ... 100	80 000	80 000	45 000	45 000	28 000	28 000
101 ... 150	80 000	80 000	40 000	32 000	25 000	20 000
151 ... 250	50 000	45 000	28 000	25 000	15 000	15 000
251 ... 400	40 000	32 000	20 000	20 000	10 000	10 000

### 3 Mixer flange

For bevel helical gearbox K.M and parallel shaft gearbox FD.M/FZ.M sizes 88 to 168

#### 3.1 Technical description

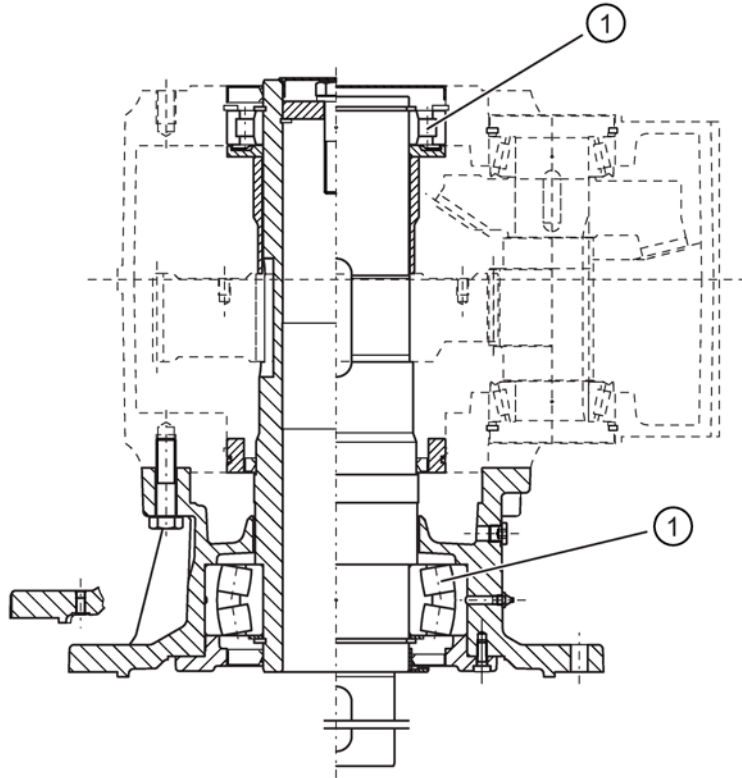

① Greased bearing

Figure 3-1 Bearing in mixer flange

The bevel helical gearbox and the parallel shaft gearbox can be supplied with an upstream mixer flange.

With an upstream locating bearing, the bearing system is suitable for high external forces. The absorbed radial and axial loads are transmitted to the machine via the mixer flange.

The bearings in the mixer flange are lubricated independently of their design. Initial greasing has already been carried out.

The mixer flange can be optionally supplied with an automatic regreasing device, see Regreasing intervals (Page 9). In this case, the output-side bearing is not sealed with NILOS rings or caps.

## 3.2 Lubrication

In normal operating conditions and with low loads, the lubrication of the bearings is sufficient for approximately 25,000 to 30,000 operating hours.

For higher loads due to speed and / or temperature, schedule regreasing at shorter intervals.

### 3.2.1 Regreasing intervals

The regreasing interval is valid for a temperature of +70 °C, measured on the surface of the housing in the vicinity of the bearing.

---

#### Note

For temperatures above +70 °C, the regreasing interval must be reduced by half for each temperature increase of 15 K.

---

#### Note

For moderate shock loading and vibration, the regreasing interval must be reduced by 20 %.

For heavy loading, the regreasing interval must be reduced by half.

---

Regrease the bearing after the following number of operating hours.

Table 3-1 Regreasing intervals in operating hours for mixer flange

Output speed $n_2$	Operating hours for size				
	88	108	128	148	168
[rpm]	[h]				
≤ 30	16 000	14 000	14 000	12 000	10 000
31 ... 50	12 000	10 000	10 000	10 000	9 000
51 ... 100	9 000	7 000	7 000	7 000	5 000
101 ... 150	7 000	5 000	5 000	4 000	4 000
151 ... 250	4 000	4 000	4 000	3 000	3 000
251 ... 400	3 000	3 000	3 000	1 000	1 000

### 3.2.2 Roller bearing grease

<b>NOTICE</b>
<b>When regreasing do not mix greases with different soap bases</b>

For regreasing, use lithium-saponified roller bearing grease NLGI 3/2.

Using a grease gun, inject the grease into the bearing point via the lubricating nipples provided.

The grease quantities listed in the table are guide values.

Table 3-2 Grease quantities for regreasing the mixer flange

Regreasing interval	Grease quantity for regreasing for size				
	88	108	128	148	168
	[g]				
After 6 months	20	30	30	50	80
After several years without operation	50	80	90	130	200

### 3.3 Maintenance of the output-side bearing in the mixer flange

#### Note

Change the grease filling of the roller bearing when you change the gearbox oil.  
For refilling, use lithium-saponified roller bearing grease NLGI 3/2.

#### Procedure

1. Dismantle the output-side bearing unit.
2. Clean the bearing.
3. Fill the bearing with the new grease up to approximately 30 % of the free bearing chamber.
4. Reassemble the bearing unit.

#### Maintenance interval after regreasing

After regreasing, the maintenance interval can be increased to the following number of operating hours.

Table 3-3 Maintenance interval in operating hours after regreasing the mixer flange

Output speed $n_2$	Operating hours for size				
	88	108	128	148	168
	[h]				
≤ 30	45 000	40 000	40 000	32 000	28 000
31 ... 50	32 000	28 000	28 000	28 000	25 000
51 ... 100	25 000	20 000	20 000	20 000	15 000
101 ... 150	20 000	15 000	15 000	10 000	10 000
151 ... 250	10 000	10 000	10 000	8 000	8 000
251 ... 400	8 000	8 000	8 000	4 000	4 000

## 4 Extruder flange

For bevel helical gearbox KAE and parallel shaft gearbox FDAE/FZAE sizes 68 to 168

### 4.1 Technical description

The bevel helical gearbox and the parallel shaft gearbox can be supplied with an upstream extruder flange.

The bearing system with a powerful, self-aligning roller bearing is suitable for high axial forces in the gearbox direction.

The extruder flange is equipped with a separate oil chamber and is filled with the same type of oil as the gearbox.

### 4.2 Types of construction

The type of construction designations are in accordance with IEC 60034-7 (Code I).

The gearbox must be operated only in the type of construction specified on the rating plate. This ensures that the correct quantity of lubricant is provided.

Explanation of symbols in type of construction diagrams:



Ventilation



Oil level



Oil drain

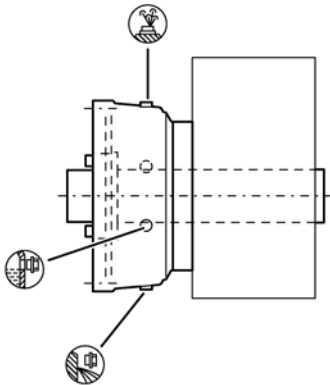

Figure 4-1 Extruder flange for types of construction H-01, H-02, H-03, H-04 for KAE and FDAE/FZAE sizes 68 - 168

## 4.3 Oil quantities

### NOTICE

#### Incorrect oil quantities damage the gearbox

The oil quantities in liters listed in the table are guide values for changing the oil. They are used, for example, for lubricant storage and procurement.

The precise oil quantities are stated on the gearbox or geared motor rating plate.

Check the oil level before commissioning.

Table 4-1 Oil quantities for extruder flange

Types of construction	Size					
	68	88	108	128	148	168
H-01, H-02, H-03, H-04	0.5	0.8	1.1	1.7	2.5	3.6

## 5 Helical gearbox with slide ring seal DU/ZU

### 5.1 Technical description

The helical gearbox with slide ring seal is delivered ready for operation with the appropriate lubricant.

It is equipped with screw plugs and is used in a closed state.

#### CAUTION

**If other sealing elements are used, moisture will enter the gearbox**

Do not exchange the screw plugs for other types of sealing element.

#### CAUTION

**Dry running will destroy the seal**

In every operating condition, the slide ring seal must be completely flushed with fluid.

**⚠ CAUTION**

**Sharp-edged parts in the sealing area destroy the seal's coating**

The flushing medium must not damage the slide ring seal.

The slide ring seal is designed according to DIN 24960. It is independent of the direction of rotation and is not balanced.

The slide ring seal is particularly suitable for media containing solids, such as waste water.

The sliding surfaces are made from silicon carbide, the bellows from fluoroelastomer (FKM). The output shaft, the featherkey and the steel parts adjacent to the slide ring seal are made from stainless steel 1.4571 (CrNiMo steel).

The pressure to be sealed  $p_{max}$  is 3 bar and the medium temperature up to +60 °C.

Operate the slide ring seal at a temperature sufficiently above the freezing point of the medium for safety.

## 5.2 Maintenance

The slide ring seal is maintenance-free.

Replace the slide ring seal as part of a plant overhaul if it is worn or disassembled.

**⚠ CAUTION**

**The protective sleeve 175 keeps coarse contamination away from the slide ring seal**

Do not seal holes and gaps.

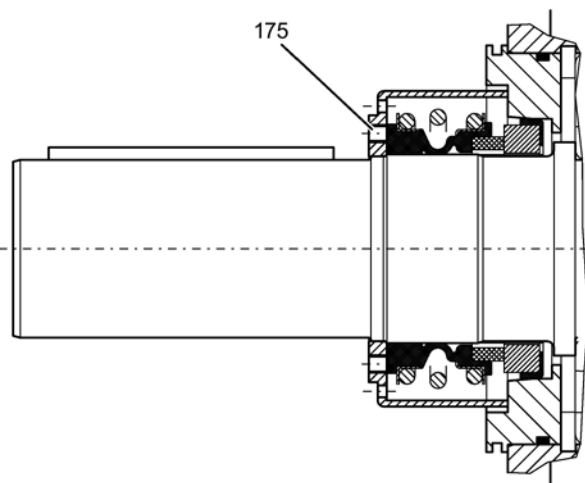

Figure 5-1 Protective sleeve for slide ring seal

## 5.3 Mounting an IEC motor

### ⚠ CAUTION

If geared motors are inadequately sealed, moisture can enter the motor

Seal the flange and bolts using an appropriate sealing compound, e.g. Loctite 574.

A flange-mounted motor must be sealed across the entire contact surface.

### Note

Exercise particular care during mounting and installation. The manufacturer cannot be held liable for damage caused by incorrect mounting and installation.

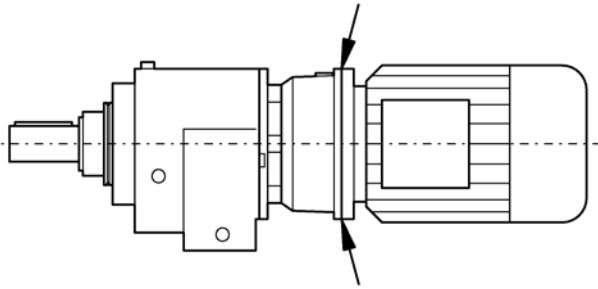

Figure 5-2 Surface to be sealed when mounting an IEC motor

### Procedure

1. Clean the surfaces to be sealed on the motor and coupling lantern.
2. Coat the entire surface with an appropriate sealing compound.
3. Flange-mount the motor to the coupling lantern and secure it using the prescribed torque.
4. Apply a suitable protective coating to the interface and the entire geared motor to prevent corrosion.

The general tolerance for the tightening torque is 10 %. The tightening torque is based on a friction coefficient of  $\mu = 0.14$ .

Table 5-1 Tightening torques for fastening bolts

Thread size	Tightening torque for strength class		
	8.8	10.9	12.9
	[Nm]	[Nm]	[Nm]
M4	3	4	5
M5	6	9	10
M6	10	15	18
M8	25	35	41
M10	50	70	85
M12	90	120	145
M16	210	295	355
M20	450	580	690
M24	750	1 000	1 200
M30	1 500	2 000	2 400
M36	2 500	3 600	4 200

## 6 Automatic regreasing device

The agitator flange and the mixer flange can be optionally supplied with an automatic regreasing device.

The automatic regreasing device can be disassembled in any position and can be used underwater.

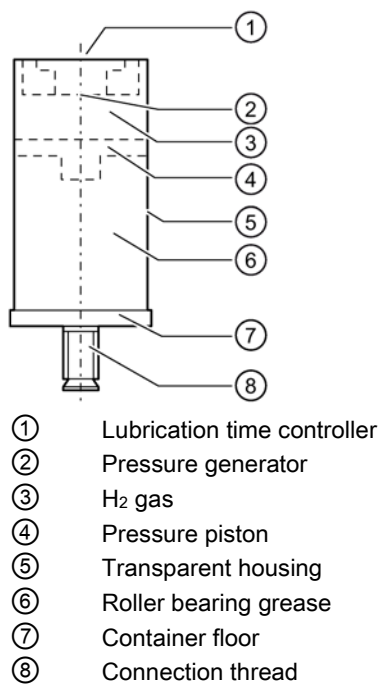

Figure 6-1 Automatic regreasing device

Table 6-1 Technical data

Grease fill quantity	125 ml
Adjustable lubrication time	0 ... 12 months
Permissible ambient temperature	-20° C ... +55° C
Maximum operating pressure	3 bar
Pressure generator	Hydrogen gas generating cell
Recommended storage temperature	+20° C
Usage period	Within 2 years of filling date
Weight including grease fill	approx. 190 g

**Commissioning**

<p><b>⚠ CAUTION</b></p> <p><b>Closed lubricator bursts</b>                  Overpressure will result if the lubricator is not opened and the grease channels are contaminated. At an overpressure of approximately 5 bar, the lubricator will burst at the preset breaking point between the housing and the funnel.                  Open the lubricator before commissioning.                  Press fresh grease into blocked channels with a grease gun.</p>
--

**Note**

Fill the lubricant channels and bearing with grease before installing the lubricator.

**Procedure**

1. Clean the area around the connection thread of the greasing point.
2. Use a knife to cut off the seal at the lubricator outlet, or remove the screw plugs.



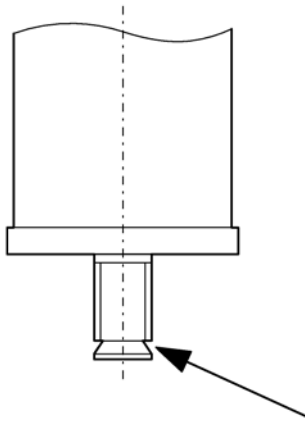

Figure 6-2 Sealing the lubricator

- Screw the lubricator into the connection thread.

### Setting the lubrication times

#### ⚠ CAUTION

##### Setting the wrong lubrication time

The lubrication time is heavily influenced by the resistance in the lubricant channels and the ambient temperature. Check the actual lubrication time during operation.

The actual lubrication time is the time it takes for the lubricator to be completely emptied. It is influenced by the resistance in the lubricant channels and the ambient temperature.

At ambient temperatures of  $-10^{\circ}\text{C}$ , the actual lubrication time is double the set lubrication time.

At ambient temperatures of  $+40^{\circ}\text{C}$ , the actual lubrication time drops to approximately half the set lubrication time.

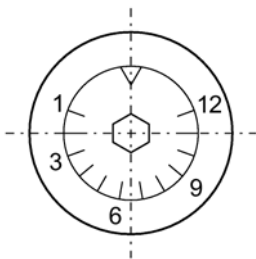

Figure 6-3 Lubrication time controller

#### Procedure

- Set the lubrication time with a 3 mm Allen key.
- Note the date of commissioning and the lubrication time on the lubricator.

The times in months listed in the table are guide values.

Table 6-2 Timing in months on the lubrication time controller

Size	68	88	108	128	148	168
Months	-	12	11	9	7	5

## 7 Labyrinth seal

The labyrinth seal is used in dusty environments. A combination of a radial shaft sealing ring ① and a labyrinth seal ② prevents the ingress of dust.

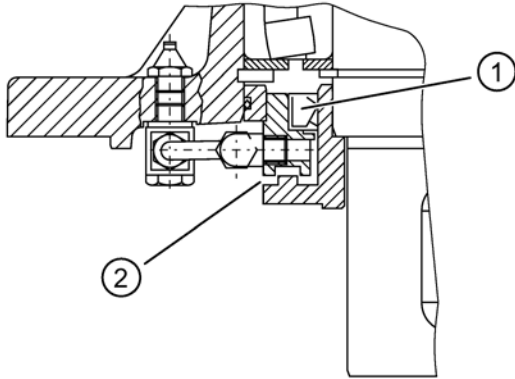

- ① Radial shaft sealing ring
- ② Labyrinth seal

Figure 7-1 Labyrinth seal

---

### Note

#### Regreasing of the labyrinth seal

The labyrinth seal is filled with grease. It must be regularly regreased depending on the ambient conditions.

---

### Procedure

1. Use the greases from table T 7300 (<http://www.steinlen.eu>) for the regreasing. The grease quality must meet the requirements specified in the table.
2. The reference value for regreasing is 30 g lubricating grease after 3000 operating hours.
3. Using a grease gun, inject the grease into the bearing point via the nipple provided.

You have regressed the labyrinth seal.

## 8 Dry-well version

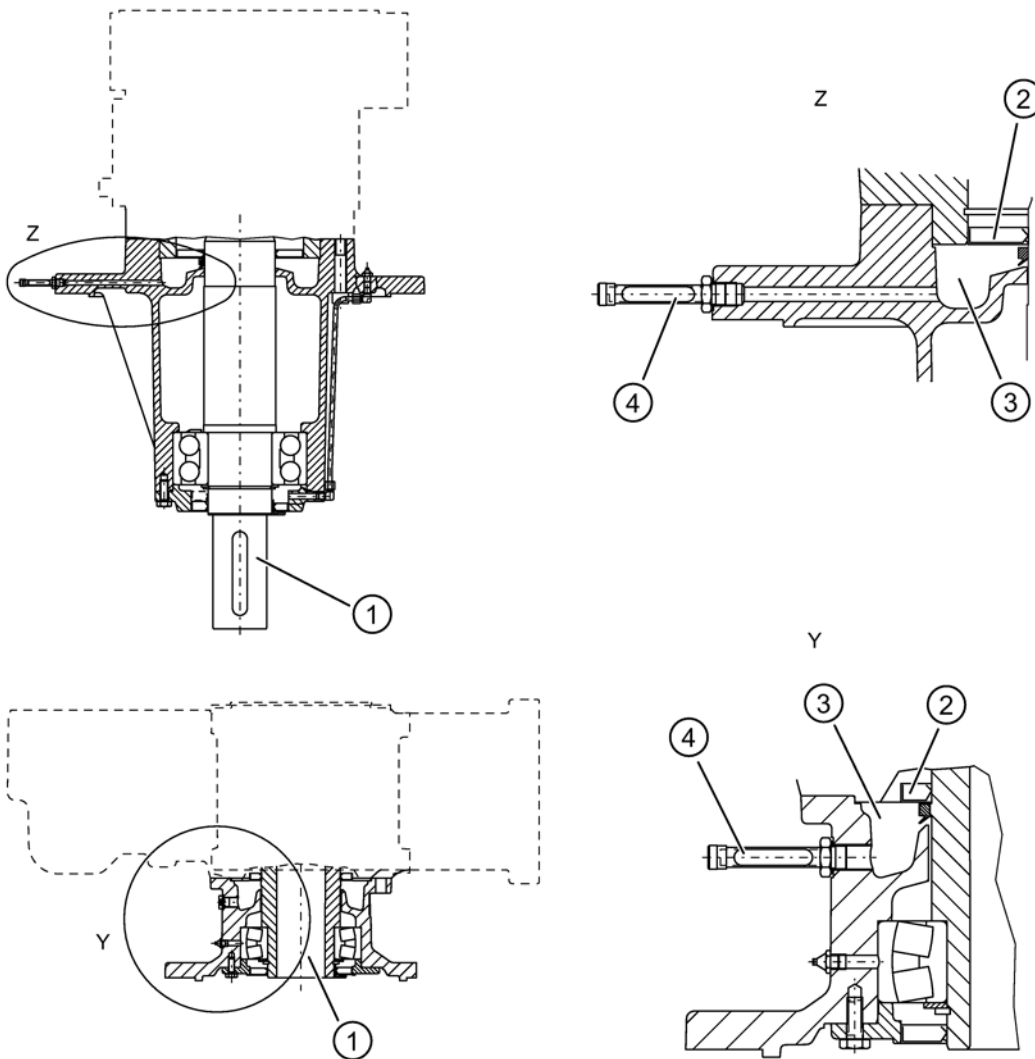

- ① Output shaft
- ② Shaft sealing ring
- ③ Oil collecting chamber of the dry-well flange
- ④ Oil sensor

Figure 8-1 Dry-well version for agitator flange and mixer flange

The dry-well version offers increased protection against oil leaks for the agitator flange and mixer flange, if the output shaft ① is pointing downwards.

If the shaft sealing ring ② fails, gearbox oil escapes. This oil is collected in a chamber ③ of the dry-well flange. An oil sensor ④ reports this optically or electronically.

## 9 Gearbox cooling

### 9.1 Heat exchanger unit

#### 9.1.1 Design and mode of operation

MOTOX helical gearboxes, parallel shaft gearboxes and bevel gearboxes can be equipped with a heat exchanger unit to reduce the temperature of the gearbox oil. The coolant that flows through the heat exchanger unit dissipates the heat.

The heat exchanger unit is mounted on the gearbox cover. The piping for feeding and extracting the coolant is connected to the cover. There is no preferred direction of flow.

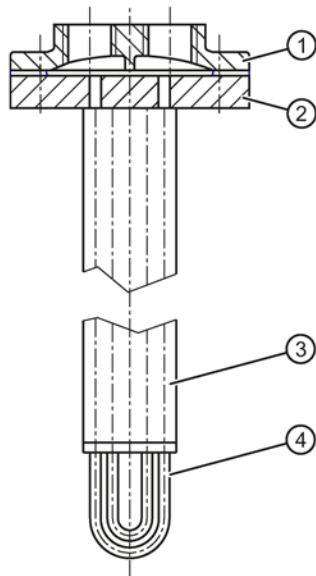

- ① Cast iron end cap
- ② Brass end plate
- ③ Aluminum cooling fins
- ④ Copper pipes

Figure 9-1 Heat exchanger unit

#### 9.1.2 Technical data

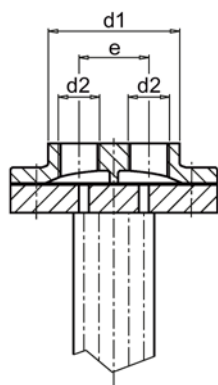



Figure 9-2 Heat exchanger unit dimensions

Table 9-1 Gearbox - heat exchanger unit

Gearbox	d1	d2	e
	[mm]	["]	[mm]
Z.128	104	R1/2	35
Z.148			
Z.168			
Z.188			
K.108			
K.128			
K.148	127	R1	39
K.168			
K.188			
FZ.108B	104	R1/2	35
FZ.128B			
FZ.148B			
FZ.168B			
FZ.188B	127	R1	39
FZ.208			

### 9.1.3 Coolant - water and oil

#### Coolant - water

 <b>CAUTION</b>
<b>Not suitable for seawater</b> The heat exchanger unit is not suitable for seawater.

 <b>CAUTION</b>
<b>Usage below 4 °C</b> The coolant must be mixed with anti-freeze. The freezing temperature of the coolant must always be lower than the possible outside temperature.

 <b>CAUTION</b>
<b>Avoid corrosion</b> The pH value of the cooling water must be $\geq 6$ . For alkaline water the water hardness should be $\geq 6^\circ\text{dH}$ .

Take the water quality and constituents into consideration when you assess the suitability of the existing water for the unit.

Do not use contaminated cooling water. If the heat exchanger unit is contaminated, a blockage may occur and this will lead to failure of the oil cooling.

Industrial water and water from streams and rivers is untreated and is not suitable as drinking water. Since this water may contain a considerable amount of chemical impurities, a water analysis is required to provide a precise assessment. Normally, copper, brass and steel are highly resistant to industrial water.

Observe the following limit values:

Flow rate - volumetric flow	Pressure	Water temperature
[l/min]	[bar]	[°C]
4 ... 17	Max. 16	5 ... 30

## Coolant - oil

The use of oil as a coolant is possible in principle. Take into account that it has a significantly lower cooling capacity than when water is used.

Steinlen Elektromaschinenbau GmbH can calculate the cooling capacity on request.

## 9.2 Oil quantities and types of construction

### NOTICE

#### **Incorrect oil quantities damage the gearbox**

The oil quantities in liters listed in the tables are guide values for changing the oil. They are used, for example, for lubricant storage and procurement.

The precise values depend on the number of stages and transmission ratio of the gearbox.

Check the oil level before commissioning.

The type of construction designations are in accordance with IEC 60034-7 (Code I).

The gearbox must be operated only in the type of construction specified on the rating plate. This ensures that the correct quantity of lubricant is provided.

Description of the symbols:



Ventilation



Oil level



Oil drain

Checking the oil level of the bevel helical gearbox deviates from BA 2010.

Use the screw plug with marking A for types of construction:

- V5-00 / H-05
- V1-00
- V3-00 / H-06

Use the screw plug with marking B for types of construction:

- B3-00 / H-01
- B8-00 / H-02
- B5-01
- B5-03

Ventilation of the bevel helical gearbox deviates from BA 2010.

Use the screw plug with marking C for types of construction:

- B6-00
- B5-00 / H-04

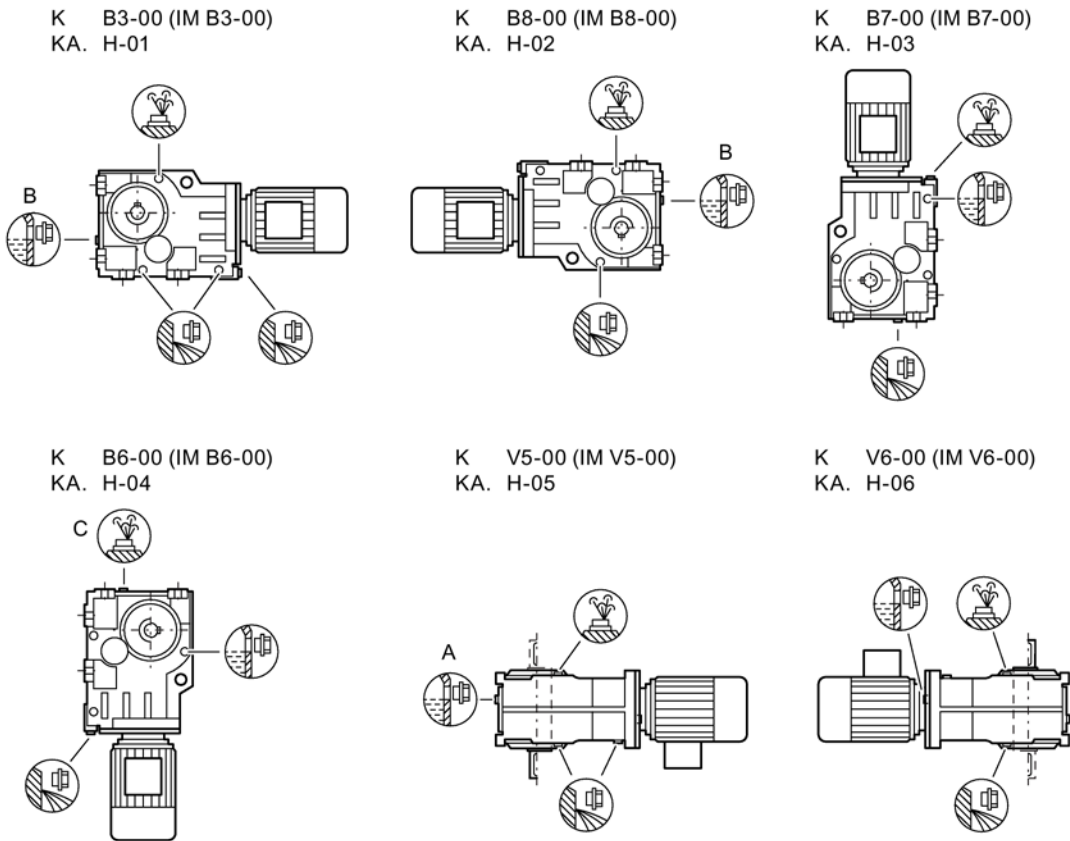

Figure 9-3 Types of construction for K, KA, KAS, KAT sizes 108 - 188

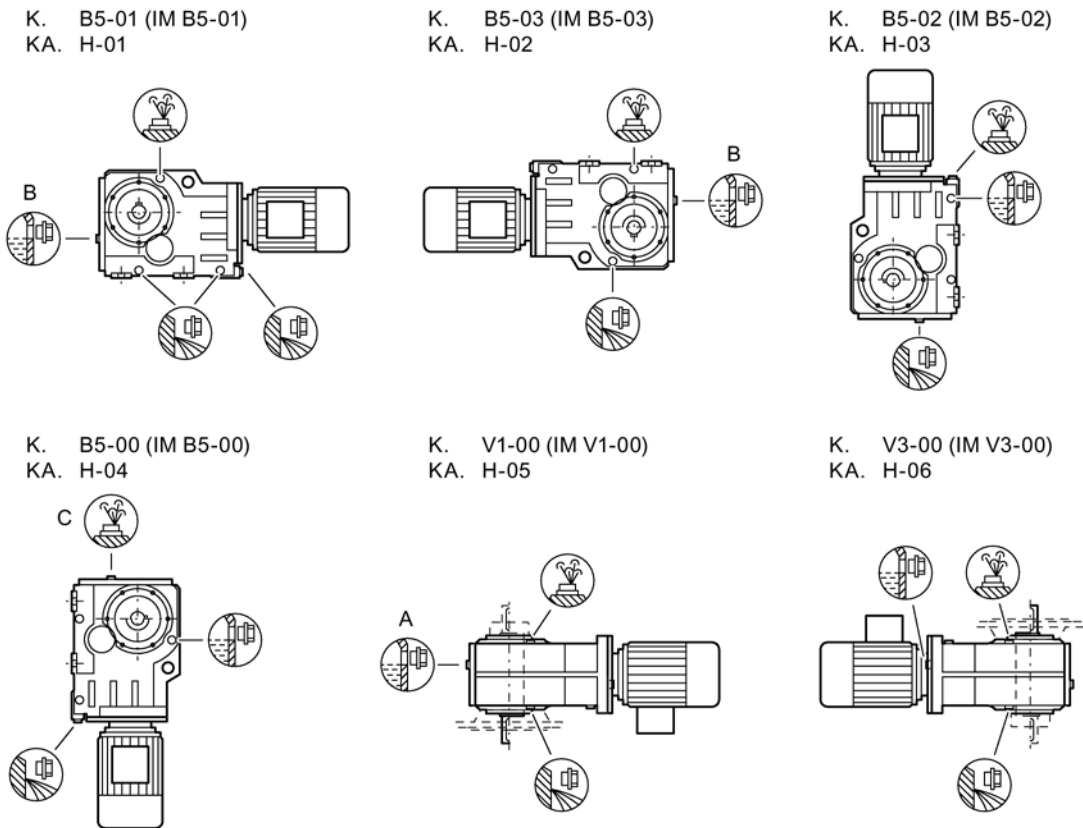

Figure 9-4 Types of construction for KZ, KF, KAD, KAZ, KAF, KADS, KAZS, KAFS, KADT, KAZT, KAFT sizes 108 - 188

## 9.3 Storage of the gearbox with heat exchanger unit

When you store the heat exchanger you have to close the coolant connections.

Empty the heat exchanger if you store it at temperatures below 4 °C.

## 10 Spare parts

### 10.1 Agitator flange

For helical gearbox DR/ZR sizes 68 to 168

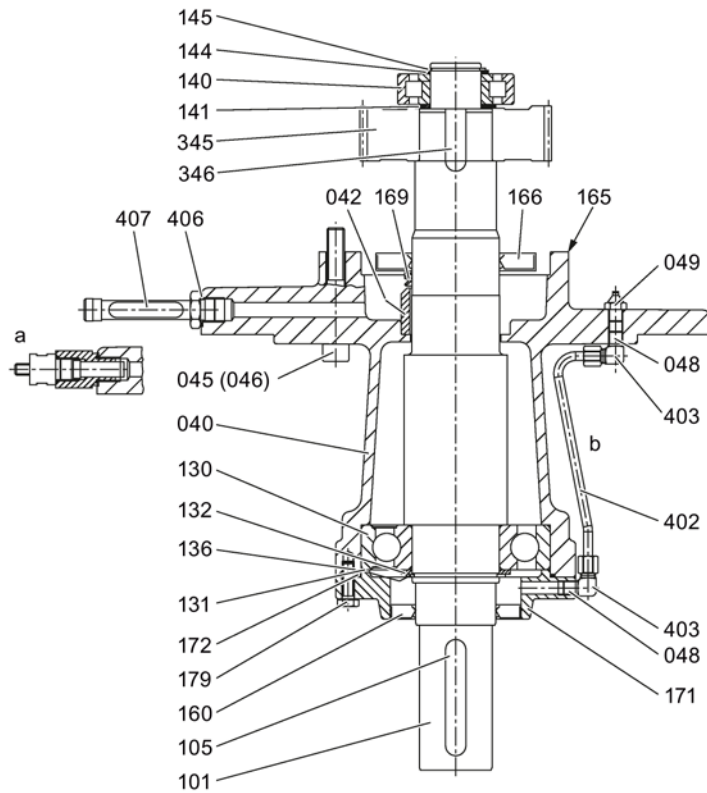

Figure 10-1 Agitator flange sizes 68 - 88



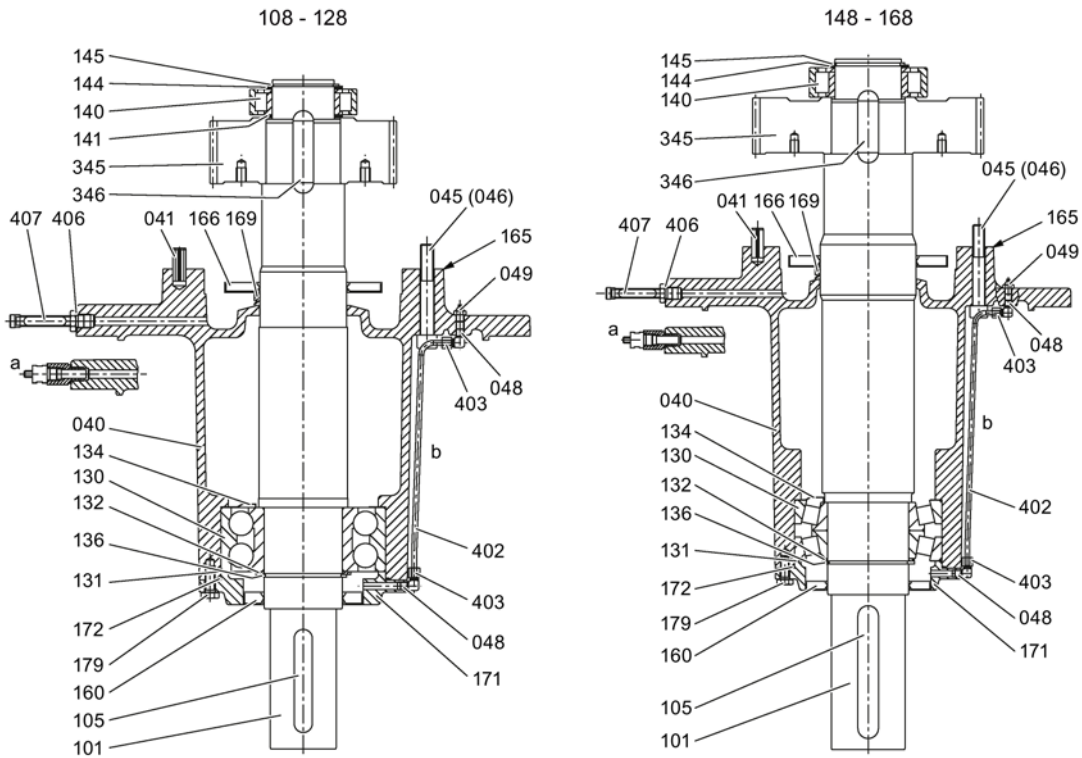

Figure 10-2 Agitator flange sizes 108 - 168

Spare parts list for agitator flange, sizes 68 to 168

a	Dry-well	b	Regreasing device
040	Output flange	144	Supporting disk / shim
041	Clamp sleeve	145	Locking ring
042	Bush	160	Shaft sealing ring
045	Screw	165	Loctite
046	Loctite	166	Shaft sealing ring
048	Screw plug	169	Axial sealing ring
049	Tapered grease nipple	171	Cover
101	Output shaft	172	O-ring
105	Parallel key	179	Screw
130	Bearing	345	Helical gear wheel
131	Supporting disk / shim	346	Parallel key
132	Supporting disk / shim	402	Grease supply tube
134	NILOS ring	403	Screwed joint
136	Locking ring	406	Seal
140	Bearing	407	Screw plug / oil sight glass
141	Supporting disk / shim		

## 10.2 Mixer flange

For bevel helical gearbox K.M and parallel shaft gearbox FD.M/FZ.M sizes 88 to 168

88

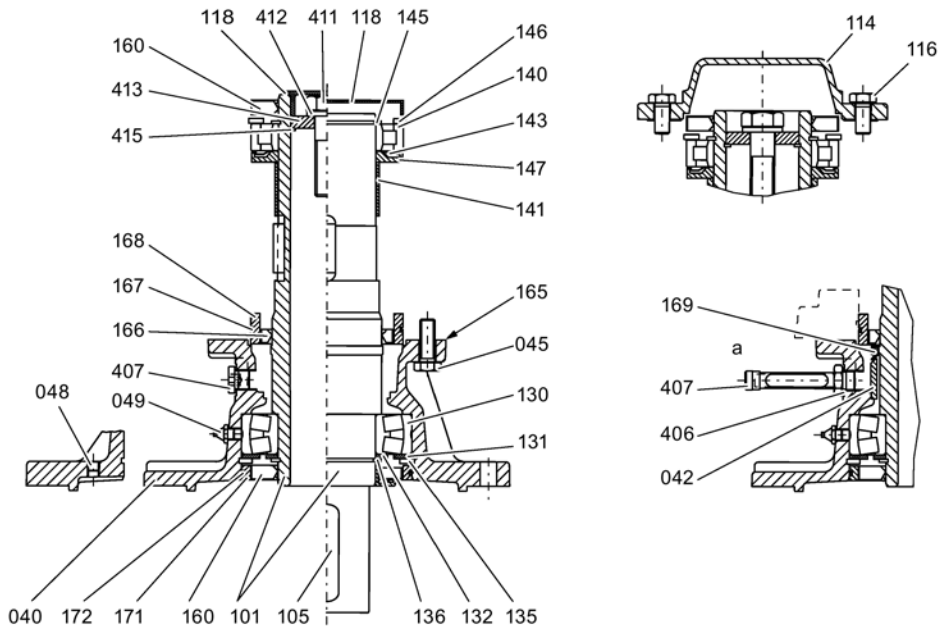

108 - 168

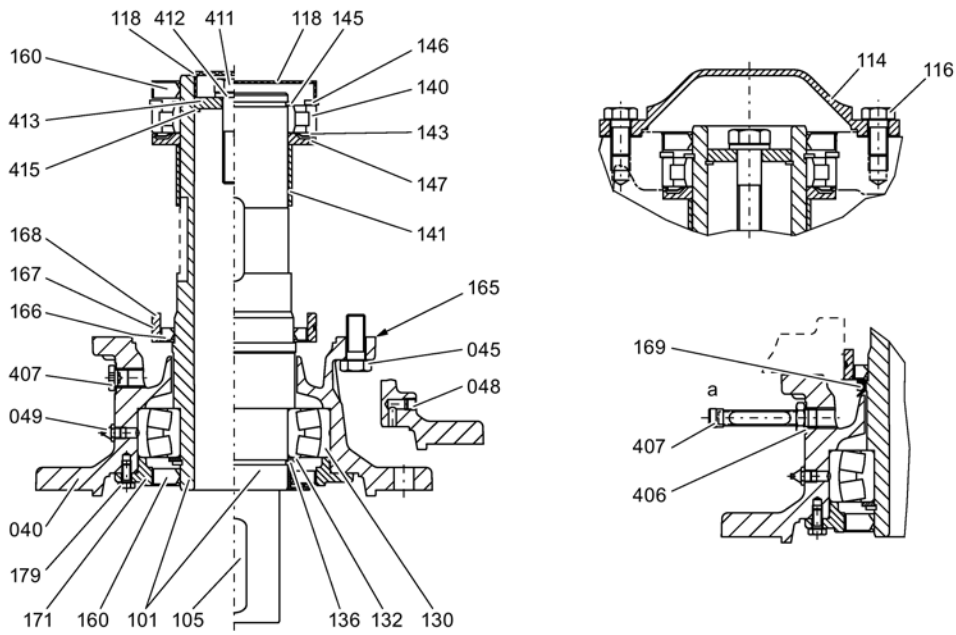

a	Dry-well		
040	Output flange	146	Locking ring
042	Bush	147	Grease deposit disk
045	Screw	160	Shaft sealing ring
048	Screw plug	165	Loctite
049	Tapered grease nipple	166	Shaft sealing ring
101	Output shaft	167	O-ring
105	Parallel key	168	Ring
114	Cover	169	Axial seal
116	Screw	171	Cover
118	Sealing cap	172	O-ring
130	Bearing	179	Screw
131	Supporting disk / shim	345	Helical gear wheel
132	Supporting disk / shim	346	Parallel key
135	Supporting disk / shim	406	Seal
136	Locking ring	407	Screw plug / oil sight glass
140	Bearing	411	Hex screw
141	Bush	412	Spring washer
143	NILOS ring	413	Disk
145	Locking ring	415	Locking ring

Figure 10-3 Mixer flange sizes 88 - 168

### 10.3 Extruder flange

For bevel helical gearbox KAE and parallel shaft gearbox FDAE/FZAE sizes 68 to 168

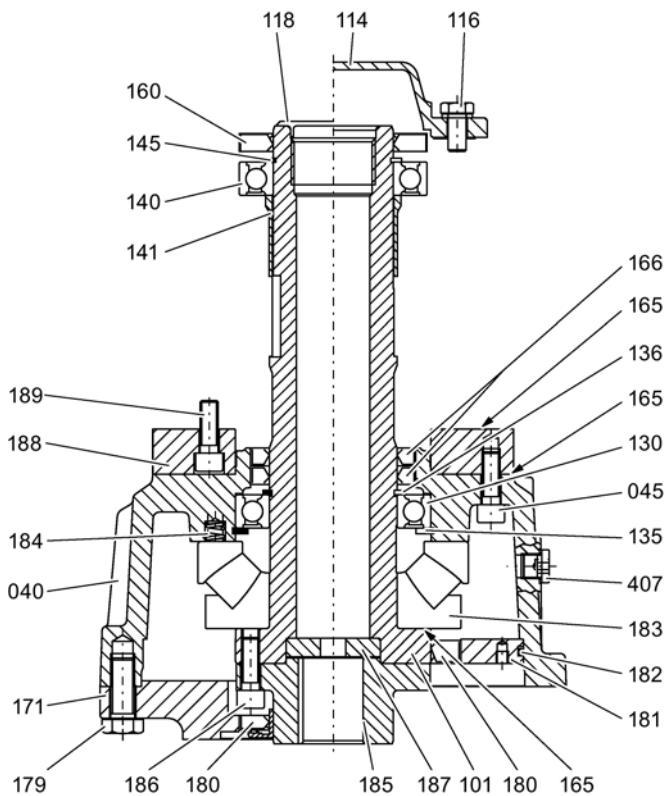

040	Extruder flange	171	Cover
045	Screw	179	Screw
101	Output shaft	180	Shaft sealing ring
114	Cover	181	Sealing washer
116	Screw	182	O ring
118	Plug	183	Axial spherical roller bearing
130	Bearing	184	Compression spring
135	Locking ring	185	Flanged hub
136	Locking ring	186	Screw
140	Bearing	187	Thrust pad
141	Bush	188	Adapter flange
145	Locking ring	189	Screw
160	Shaft sealing ring	345	Helical gear wheel
165	Loctite	346	Parallel key
166	Shaft sealing ring	407	Screw plug / oil sight glass

Figure 10-4 Extruder flange sizes 68 - 168

## 10.4 Labyrinth seal

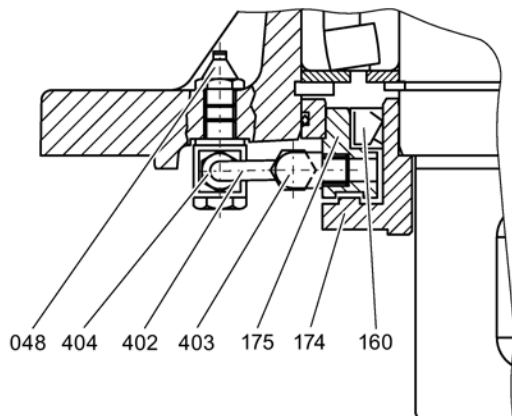

048	Tapered grease nipple	402	Grease tube
160	Shaft sealing ring	403	Screwed joint
174	Outer ring	404	Screwed joint
175	Inner ring		

Figure 10-5 Labyrinth seal

## 10.5 Dry-well version

Size 88

Sizes 108 - 168

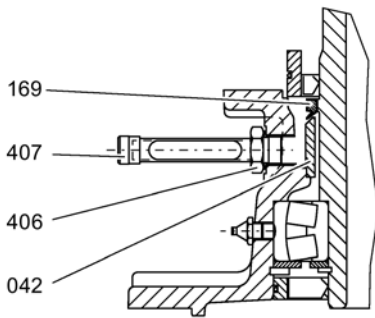

042 Bush  
169 Axial sealing ring

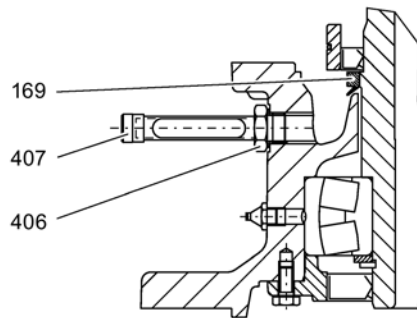

406 Seal  
407 Screw plug / oil sight glass

Figure 10-6 Dry-well version

---

### Trademarks

All names identified by ® are registered trademarks of Steinlen Elektromaschinenbau GmbH. The remaining trademarks in this publication may be trademarks whose use by third parties for their own purposes could violate the rights of the owner.

### Disclaimer of Liability

We have reviewed the contents of this publication to ensure consistency with the hardware and software described. Since variance cannot be precluded entirely, we cannot guarantee full consistency. However, the information in this publication is reviewed regularly and any necessary corrections are included in subsequent editions.

Steinlen Elektromaschinenbau GmbH  
Ehlbeek 21  
30938 BURGWEDEL  
GERMANY

BA 2510  
A5E38121849A/RS-AC-ST, 03/2021

Steinlen Elektromaschinenbau GmbH  
Ehlbeek 21  
30938 Burgwedel  
Germany

Phone:  
+49 (0)51 39 / 80 70-0

E-Mail:  
[info@steinlen.de](mailto:info@steinlen.de)